

2022
DATE
March 23th

TEGGA
TIME
9:00-ONLINE

線上演講

主題 中壓快速充電器發展 (Medium-Voltage Fast Charger Development)

講者  **賴日生 博士** (Prof. Jason Lai, IEEE Life Fellow) 維吉尼亞理工Tucker講座教授
新加坡南洋理工大學客座教授
國立陽明交通大學玉山學者客座講座教授

Medium-Voltage Fast Charger

Abstract

With wide bandgap semiconductor devices available, applying power electronics for utility-scale medium-voltage systems can achieve high-efficiency and cost-effective designs. Utility medium-voltage level ranges from **2.4 kV to 34.5 kV**. Although the voltage levels of power semiconductor devices are only available at 6.5 kV or less. It is possible to use cascaded approach to synthesize a much higher voltage level. Two of our recently developed systems are rated **7.2 kV phase-to-neutral and 12.47 kV line-to-line**. They can be used for high-voltage high-power PV systems and EV fast chargers. This talk will mainly discuss the circuit architecture and key performance of the proposed medium-voltage inverters for EV fast charge applications. The market of fast chargers will be projected to justify the work, and the business model to bring these medium-voltage technologies to Taiwan will also be discussed.

About the Presenter

Jih-Sheng (Jason) Lai received M.S. and Ph.D. degrees in electrical engineering from the University of Tennessee, Knoxville, in 1985 and 1989. After graduated, he joined Electric Power Research Institute (EPRI) Power Electronics Applications Center (PEAC). From 1993, he worked with the Oak Ridge National Laboratory as the Power Electronics Lead Scientist. In 1996, he switched to academia and joined Virginia Tech. Currently he is James S. Tucker Professor and Director of Future Energy Electronics Center (FEEC). He published more than 500 refereed technical papers and received more than 30 U.S. patents in the area of high power electronics and their applications. Dr. Lai is an IEEE Life Fellow. He received numerous awards including a Technical Achievement Award in 1995-Lockheed Martin Award Night and 2016-IEEE Gerald Kliman Innovation Award. His student teams won grand prizes in 2009 TI Engibous Analog Design Competition and 2011 IEEE International Future Energy Challenge. In 2016 Google Little Box Challenge, his team won the Top 3 Finalist among 2000 international teams.



國際技術講座一

中壓快速充電器發展 (Medium-Voltage Fast Charger Development)

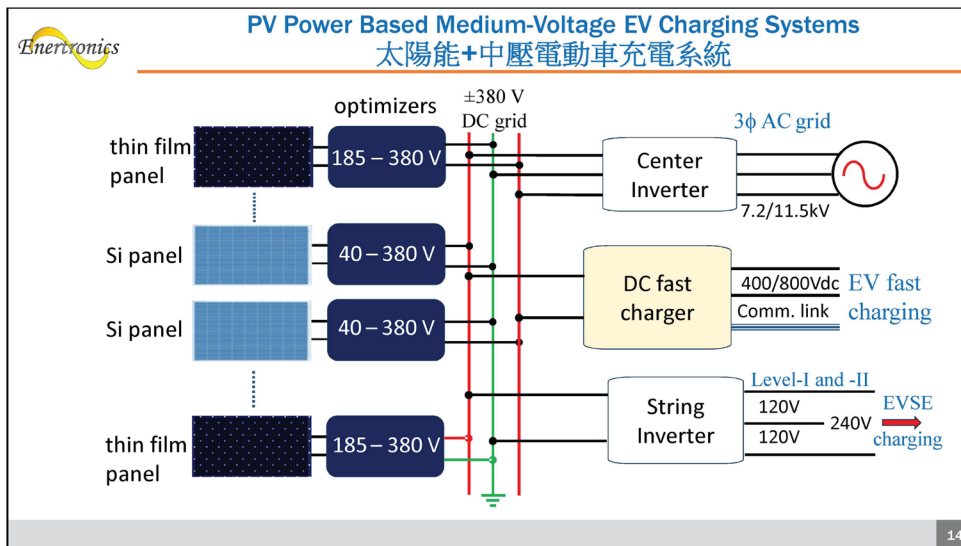

賴日生博士 (Prof. Jason Lai, IEEE Life Fellow)

維吉尼亞理工 Tucker 講座教授

新加坡南洋理工大學客座教授

國立陽明交通大學玉山學者客座講座教授

論壇報名連結：<https://forms.gle/81qsuYSgjjAdnXqo7>

課程資訊：日期: 2022 年 3/23 星期三-早上九點

主辦單位一

科技部新能源電動車產學技術聯盟

國立中興大學智慧運輸發展中心

國立中興大學智慧電動車及綠能科技中心

台灣智慧電動車及綠能科技協會

科技部新能源電動車產學技術聯盟很榮幸邀請到全球知名電力電子專家、台灣旅美學者賴日生博士，分享直接中壓電網之雙向快速充電器技術發展的經驗，該學研成果由美國能源署(DOE)之重視發展與經費補助，對於電動車及儲能業者於高效率、快速充電議題已帶來革命性的影響；本聯盟協助進行橋接台美技術與授權媒合。

國立中興大學智慧電動車及綠能科技中心

科技部新能源電動車產學技術聯盟 計畫主持人

賴慶明教授 pecmlai@gmail.com